

Tolerances 1-20=+/-0.2 20-30=+/-0.3 30-40=+/-0.4 40-50=+/-0.5 50-100=+/-0.75 100-300=+/-1.5 Angles=+/-1 Dimensions are in Millimeters	Revisions Description/Approved/Date	Approved M.H.	Date 3/11/03
		Checked M.H.	Date 3/11/03
		Drawn K.R.E.	Date 3/11/03
NOTES (plating thickness in micro-inches): 1. Per QQ-B-626 2. Per QQ-S-764 3. Per QQ-C-530 4. Per QQ-B-750 5. Per MIL-P-19468 6. Per ZZ-R-765 7. Per WW-T-799 8. Gold pl. 5 min. over nickel pl. 50 min. over copper strike 9. Nickel pl. 100 min. over copper strike 10. Per QQ-P-35 11. Gold pl. 5 min. over nickel pl. 50 min. over copper strike			

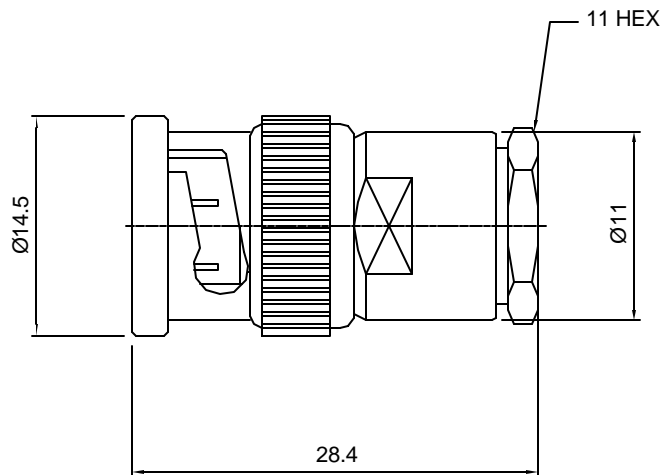

ITEM	MATERIAL	FINISH
Connector Body	Brass, Note 1	Nickel, Note 9
Center Contact:	Brass, Note 1	Gold, Note 11
Insulation	Teflon, Note 5	None
Ferrule	-	-
Gasket	Silicone Rubber, Note 6	-
Hex Nut	-	-
Lock Washer	-	-

	Lighthouse Technologies, Inc. 4907 Morena Boulevard, #1411 San Diego, California 92117	
	Part Number: LTI-BSM21NT-58	
Description BNC Clamp on style Plug for RG 58		
Scale 1:1	Drawing No. BSM11NT	File Name bsm21nt