

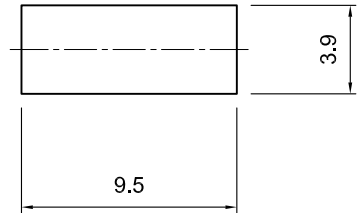

Tolerances
 1-20=+/-0.2
 20-30=+/-0.3
 30-40=+/-0.4
 40-50=+/-0.5
 50-100=+/-0.75
 100-300=+/-1.5
 Angles=+/-1
Dimensions are in Millimeters

Revisions Description/Approved/Date	Approved M.H.	Date 12/13/02
	Checked M.H.	Date 12/13/02
	Drawn K.R.E.	Date 12/13/02
NOTES (plating thickness in micro-inches): 1. Per QQ-B-626 2. Per QQ-S-764 3. Per QQ-C-530 4. Per QQ-B-750 5. Per MIL-P-19468 6. Per ZZ-R-765 7. Per WW-T-799 8. Gold pl. 5 min. over nickel pl. 50 min. over copper strike 9. Nickel pl. 100 min. over copper strike 10. Per QQ-P-35 11. Gold pl. 30 min. over nickel pl. 50 min. over copper strike		

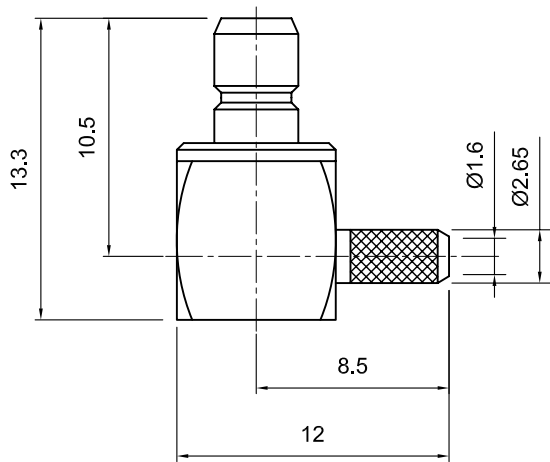

ITEM	MATERIAL	FINISH
Connector Body	Brass, Note 1	Gold, Note 8
Center Contact: M	Brass, Note 1	Gold, Note 11
Insulation	Teflon, Note 5	None
Ferrule	Annealed Copper, Note 7	Same as body
Gasket	--	--
Hex Nut	--	--
Lock Washer	--	--



Lighthouse Technologies, Inc.
 5640 Kearny Mesa Rd. Suite N
 San Diego, California 92111
 Part Number:
LTI-SBLF11GT-316

Description
 SMB right angle crimp jack for RG 316. Gold plated brass
 body, Teflon dielectric.

Scale 3:1	Drawing No. SBLF11GT-316	File Name SBLF11-316
--------------	-----------------------------	-------------------------