

All components used in this connector conform to RoHS standards.



Tolerances
 1-20=+/-0.2
 20-30=+/-0.3
 30-40=+/-0.4
 40-50=+/-0.5
 50-100=+/-0.75
 100-300=+/-1.5
 Angles=+/-1
Dimensions are in Millimeters

Revisions Description/Approved/Date	Approved	Date
	Checked	Date
	Drawn S.A.	Date 10/22/08
NOTES (plating thickness in micro-inches): 1. Per QQ-B-626 2. Per QQ-S-764 3. Per QQ-C-530 4. Per QQ-B-750	5. Per MIL-P-19468 6. Per ZZ-R-765 7. Per WW-T-799 8. Gold pl. 5 min. over nickel pl. 50 min. over copper strike	9. Nickel pl. 100 min. over copper strike 10. Per QQ-P-35 11. Gold pl. 30 min. over nickel pl. 50 min. over copper strike

Approved by:
Date:

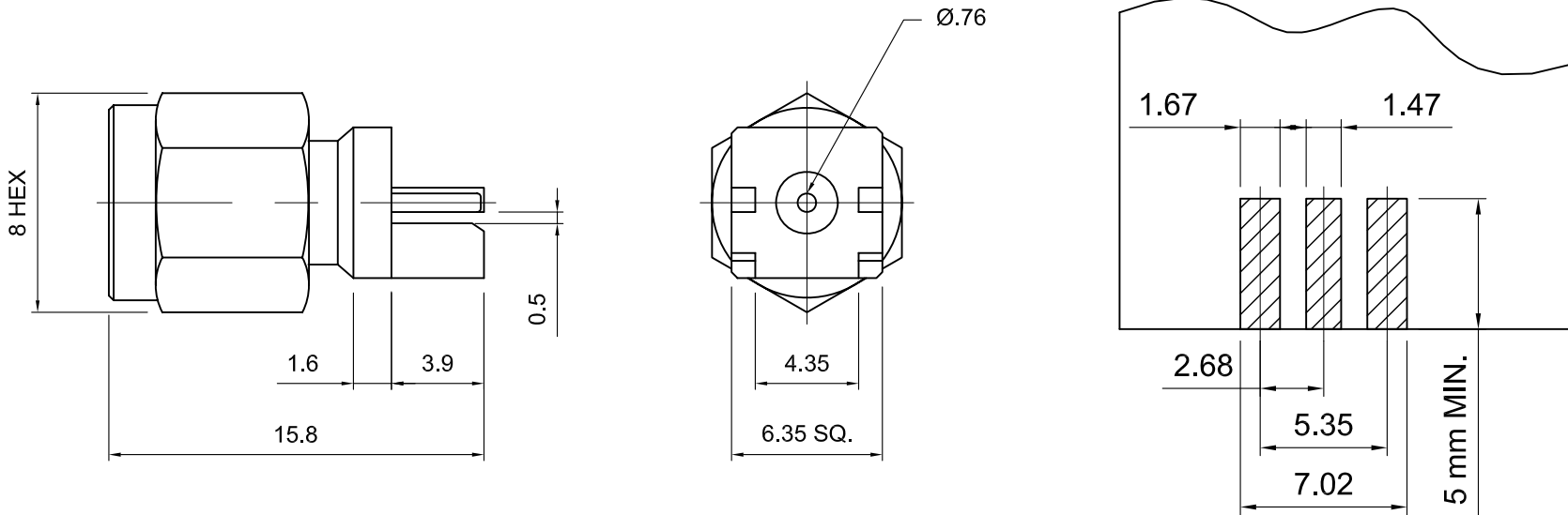

ITEM	MATERIAL	FINISH
Connector Body	Brass, Note 1	Gold, Note 8
Center Contact: M	Brass, Note 11	Gold, Note 11
Insulation	Teflon, Note 5	None
Ferrule	--	--
Gasket	--	--
Hex Nut	--	--
Lock Washer	--	--

Lighthouse Technologies, Inc.
 9511 Ridgeway Court, Suite B
 San Diego, California 92123

Part Number:
SASM55GT-2

Description SMA end launch PCB plug for 0.020" board. Gold plated Brass body		
Teflon dielectric.		
Scale 3:1	Drawing No. SASM55GT-2	File Name SASM55GT-2