

Revisions		Approved	Date
Description/Approval/Date	Checked		Date
	Drawn	S.A.	10/23/08

  

Tolerances	
1-20=+/-0.2	
20-30=+/-0.3	
30-40=+/-0.4	
40-50=+/-0.5	
50-100=+/-0.75	
100-300=+/-1.5	
Angles=+/-1	

**Dimensions are in Millimeters**

  

NOTES (plating thickness in microinches):	
1. Per QQ-B-626	6. Per ZZ-R-765
2. Per QQ-S-764	7. Per WW-1-799
3. Per QQ-C-530	8. Gold pl. 5 min. over nickel pl. 50 min. over copper strike
4. Per QQ-B-750	9. Nickel pl. 100 min. over copper strike
	10. Gold pl. 5 min. over nickel pl. 50 min. over copper strike
	11. Gold pl. 5 min. over nickel pl. 50 min. over copper strike

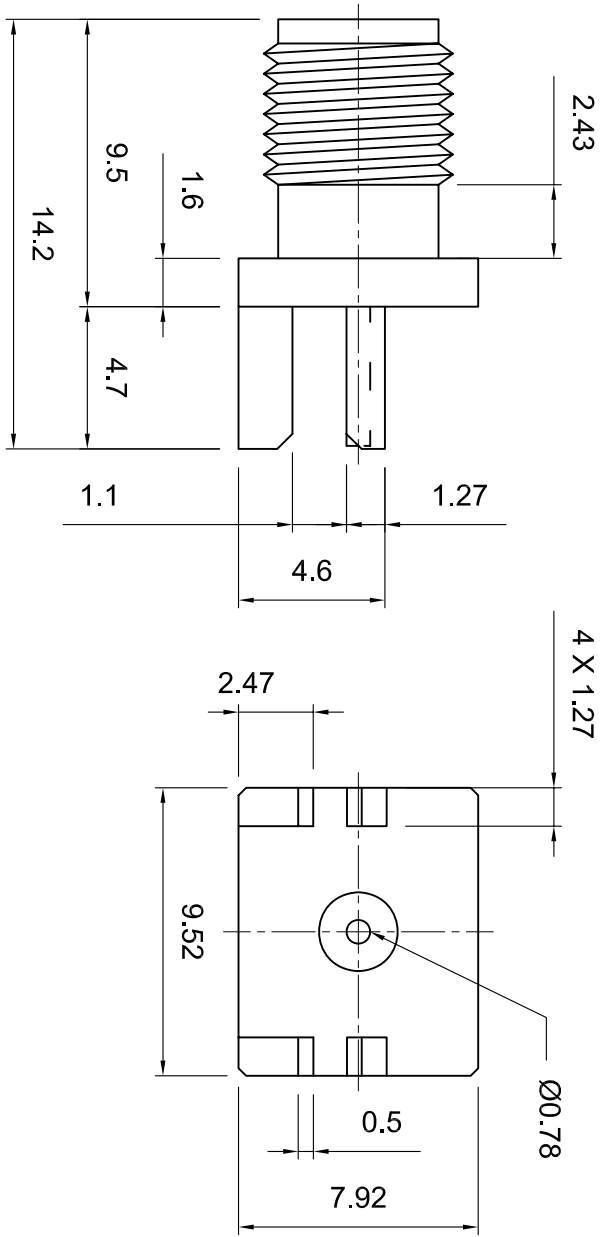

ITEM	MATERIAL	FINISH
Connector Body	Brass, Note 1	Gold, Note 8
Center Contact:	Brass, Note 1	Gold, Note 11
Insulation	Teflon, Note 5	None
Ferrule	Annealed Copper, Note 7	Same as body
Gasket	Silicone Rubber, Note 6	None
Hex Nut	Brass, Note 1	Same as body
Lock Washer		Same as body

 <b>Lighthorse Technologies, Inc.</b> 9511 Ridgely Court, Suite B San Diego, CA 92123 Part Number: <b>LTI-SASF95ZGT-4</b>	Description
	SMA end launch jack for .042" PCB, wide flange, short version
Scale	1:1
Drawing No.	LTI-SASF95ZGT-4
File Name	LTI-SASF95ZGT-4