

Tolerances	
1-20=+/-0.2	
20-30=+/-0.3	
30-40=+/-0.4	
40-50=+/-0.5	
50-100=+/-0.75	
100-300=+/-1.5	
Angles=+/-1	

Dimensions are in Millimeters

Revisions	Approved	Date
Description/Approval/Date	Checked	Date
	Drawn	Date
	S/A	

NOTES (plating thickness in microinches):

- Per QQ-B-626
- Per QQ-S-764
- Per QQ-C-530
- Per QQ-B-750
- Per MIL-P-19488
- Per ZZ-R-765
- Per WW-1-799
- Gold pl. 5 min. over nickel pl. 50 min. over copper strike
- Nickel pl. 100 min. over copper strike
- Per QQ-P-35
- Gold pl. 5 min. over nickel pl. 50 min. over copper strike

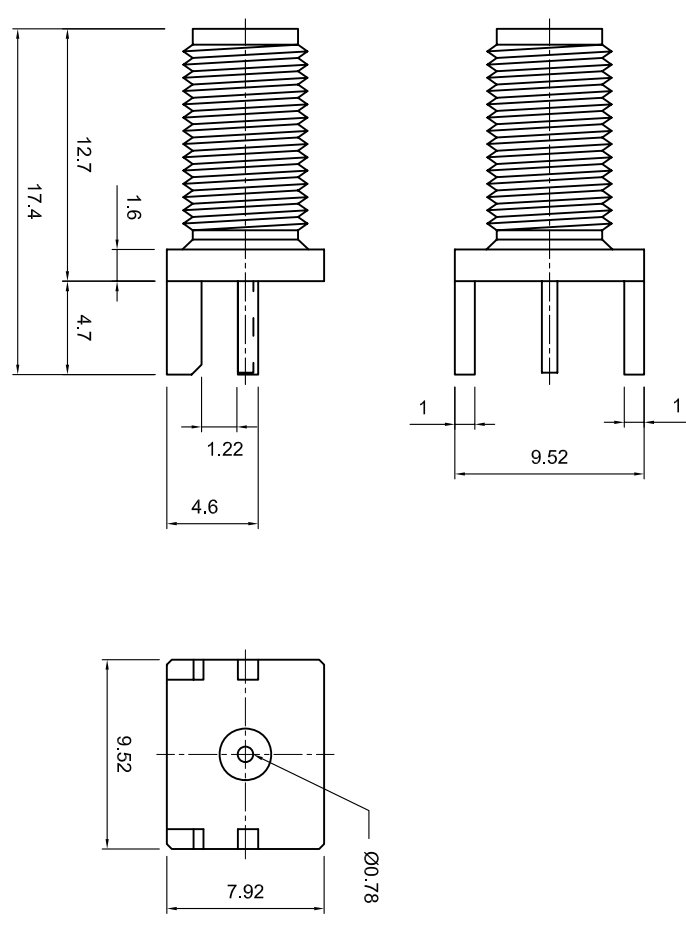

ITEM	MATERIAL	FINISH
Connector Body	Brass, Note 1	Gold, Note 8
Center Contact: Female	BeCu, Note 3	Gold, Note 11
Insulation	Teflon, Note 5	None
Ferrule	--	--
Gasket	--	--
Hex Nut	--	--
Lock Washer	--	--



Lighthorse Technologies, Inc.
9511 Ridgely Court, Suite B
San Diego, CA 92123

Part Number:
LTI-SASF95MGT-5

Description SMA End Launch Jack, Medium Barrel Length, wide flange		
for 0.048" PCB		
Scale	Drawing No.	File Name
1:1	SASF95MGT-5	SASF95MGT-5