

Revisions	Approved	Date
Description/Approval/Date	Checked	Date
	Drawn	Date
	S.A.	10/22/08

Tolerances
1-20=+/-0.2
20-30=+/-0.3
30-40=+/-0.4
40-50=+/-0.5
50-100=+/-0.75
100-300=+/-1.5
Angles=+/-1

Dimensions are in Millimeters

NOTES (plating thickness in microinches):
1. Per QQ-B-626
2. Per QQ-S-764
3. Per QQ-C-530
4. Per QQ-B-750
5. Per MIL-P-19488
6. Per ZZ-R-765
7. Per WW-1-799
8. Gold pl. 5 min. over nickel pl. 50 min. over copper strike
9. Nickel pl. 100 min. over copper strike
10. Per QQ-P-35
11. Gold pl. 30 min. over nickel pl. 50 min. over copper strike

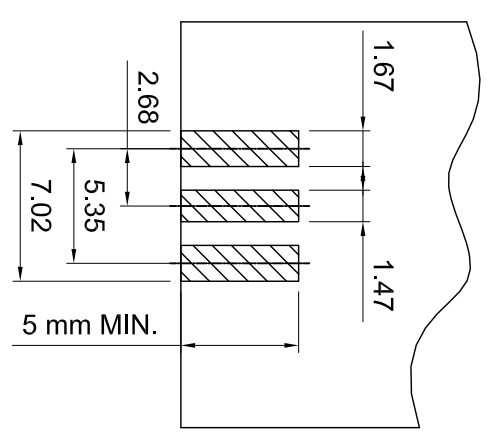
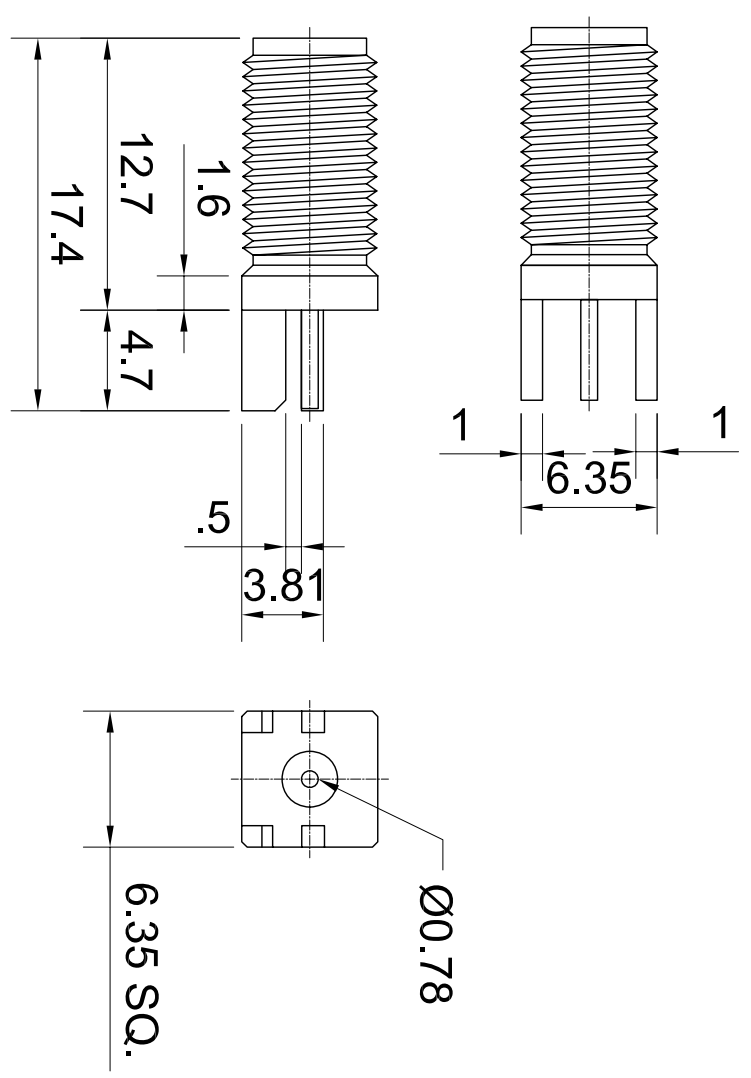

ITEM	MATERIAL	FINISH
Connector Body	Brass, Note 1	Gold, Note 8
Center Contact: Female	BeCu, Note 3	Gold, Note 11
Insulation	Teflon, Note 5	None
Ferrule	--	--
Gasket	--	--
Hex Nut	--	--
Lock Washer	--	--

Lighthorse Technologies, Inc.
9511 Ridgely Court, Suite B
San Diego, CA 92123

Part Number:
LTI-SASF55MGT-2

Description SMA end launch jack for .020 mil board, medium version.		
Gold plated brass body, Teflon dielectric.		
Scale	Drawing No.	File Name
3:1		SASF55MGT-2