

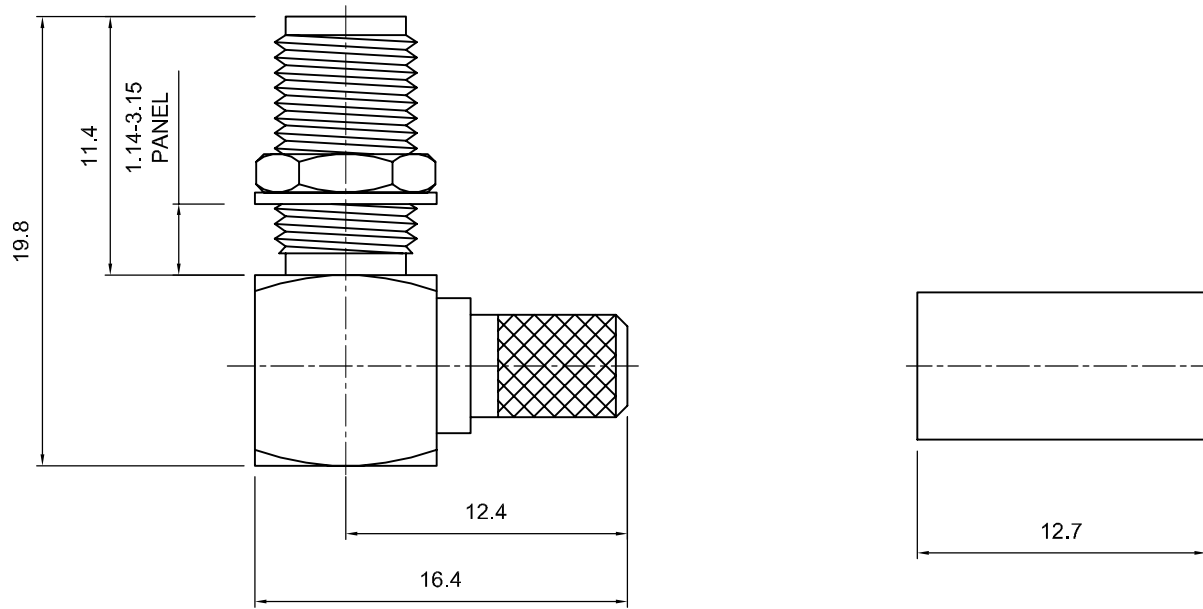

	Tolerances 1-20=+/-0.2 20-30=+/-0.3 30-40=+/-0.4 40-50=+/-0.5 50-100=+/-0.75 100-300=+/-1.5 Angles=+/-1 Dimensions are in Millimeters	Revisions	Approved	Date
		Description/Approved/Date	M.H.	10/20/02
			Checked	Date
			M.H.	10/20/02
		Drawn	Date	
		K.R.E.	10/20/02	
NOTES (plating thickness in micro-inches):		5. Per MIL-P-19468	9. Nickel pl. 100 min. over copper strike	
1. Per QQ-B-626	6. Per ZZ-R-765	7. Per WW-T-799	10. Per QQ-P-35	
2. Per QQ-S-764	8. Gold pl. 5 min. over nickel pl. 50 min. over copper strike	11. Gold pl. 5 min. over nickel pl. 50 min. over copper strike		
3. Per QQ-C-530				
4. Per QQ-B-750				



ITEM	MATERIAL	FINISH	Lighthouse Technologies, Inc.		
Connector Body	Brass, Note 1	Gold, Note 8	 5640 Kearny Mesa Road, Suite N San Diego, California 92111	Part Number: LTI-SALF13GT-316	
Center Contact: Female	Beryllium Copper, Note 3	Gold, Note 11			
Insulation	Teflon, Note 5	None	Description		
Ferrule	Annealed Copper, Note 7	Same as body	Right angle crimp jack for RG 316 cable.		
Gasket	-	-	Gold plated, brass body, teflon dielectric.		
Hex Nut	Brass, Note 1	Same as body	Scale	Drawing No.	File Name
Lock Washer	Brass, Note 1	Same as body	3:1		SALF13