

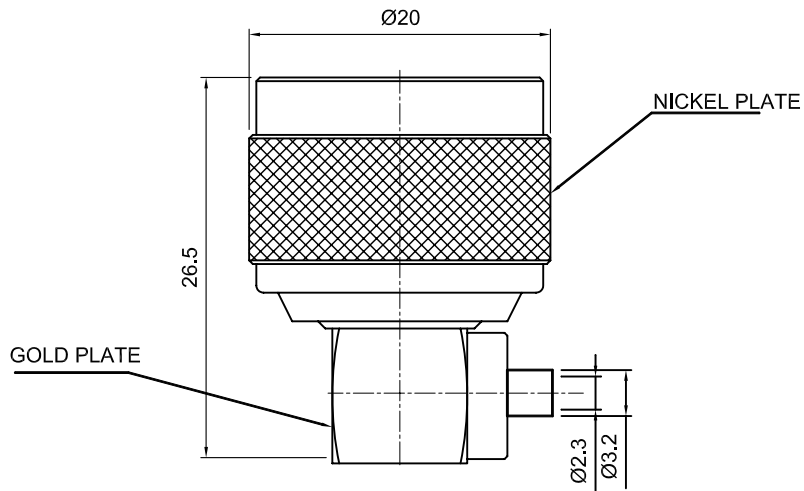

	<b>Tolerances</b> 1-20=+/-0.2 20-30=+/-0.3 30-40=+/-0.4 40-50=+/-0.5 50-100=+/-0.75 100-300=+/-1.5 Angles=+/-1 <b>Dimensions are in Millimeters</b>	Revisions	Approved	Date
		Description/Approved/Date	M.H.	
			Checked	Date
			M.H.	
		Drawn	Date	
		T.J.A.	08/23/2007	
NOTES (plating thickness in micro-inches):		5. Per MIL-P-19468	9. Nickel pl. 100 min. over copper strike	
1. Per QQ-B-626	6. Per ZZ-R-765	10. Per QQ-P-35		
2. Per QQ-S-764	7. Per WW-T-799	11. Gold pl. 30 min. over nickel pl. 50 min. over copper strike		
3. Per QQ-C-530	8. Gold pl. 5 min. over nickel pl. 50 min. over copper strike			
4. Per QQ-B-750				



ITEM	MATERIAL	FINISH	Lighthouse Technologies, Inc.		
Connector Body	Brass, Note 1	Nickel, Note 9	 5640 Kearny Mesa Road, Suite N San Diego, California 92111 Part Number: <b>LTI-NLM31NT-086</b>	Description	
Center Contact: Male	Brass, Note 1	Gold, Note 11		N right angle solder plug for .086" semi-rigid cable	
Insulation	Teflon, Note 5	None			
Ferrule	--	--	Scale	Drawing No.	File Name
Gasket	--	--	2:1	N/NLM31-086	NLM31-086
Hex Nut	--	--			
Lock Washer	--	--			