

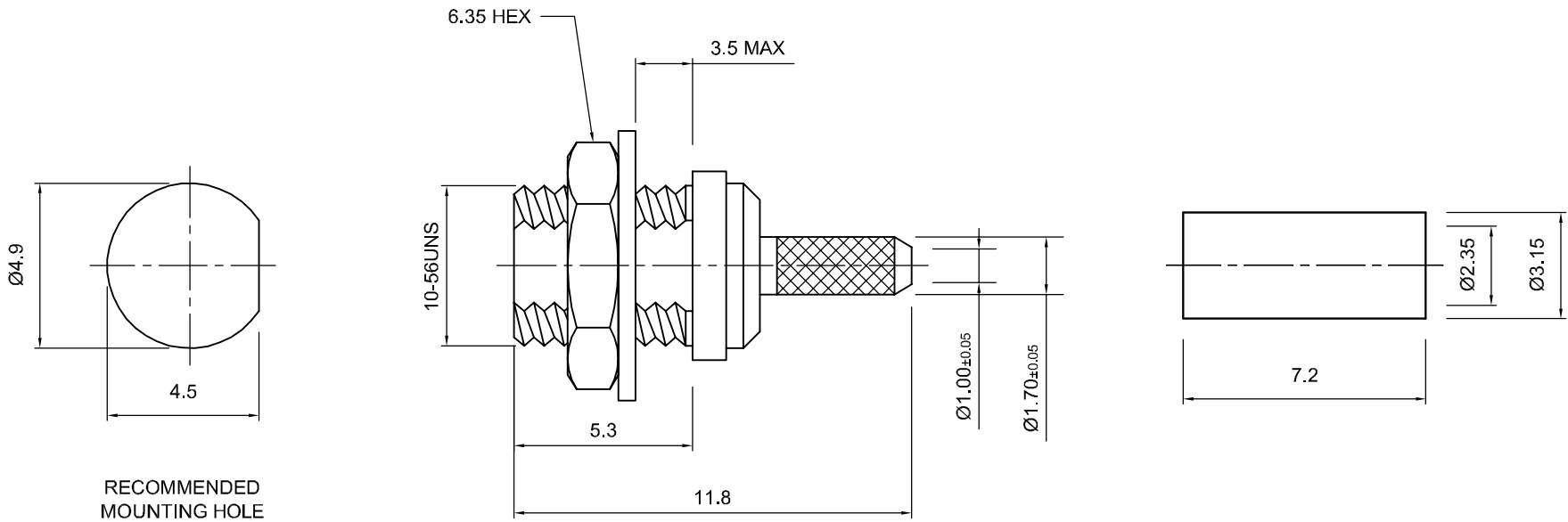

	Tolerances 1-20=+/-0.2 20-30=+/-0.3 30-40=+/-0.4 40-50=+/-0.5 50-100=+/-0.75 100-300=+/-1.5 Angles=+/-1 Dimensions are in Millimeters	Revisions	Approved	Date
		Description/Approved/Date	M.H.	03/17/02
			Checked	Date
			M.H.	03/17/02
		Drawn	Date	
		K.R.E.	03/14/02	
NOTES (plating thickness in micro-inches):		5. Per MIL-P-19468	9. Nickel pl. 100 min. over copper strike	
1. Per QQ-B-626	6. Per ZZ-R-765	7. Per WW-T-799	10. Per QQ-P-35	
2. Per QQ-S-764	8. Gold pl. 5 min. over nickel pl. 50 min. over copper strike		11. Gold pl. 30 min. over nickel pl. 50 min. over copper strike	
3. Per QQ-C-530				
4. Per QQ-B-750				



ITEM	MATERIAL	FINISH	Lighthouse Technologies, Inc.		
Connector Body	Brass, Note 1	Gold, Note 8	 5640 Kearny Mesa Road, Suite N San Diego, California 92111 Part Number: LTI-MCSF13GT-178		
Center Contact: Female	Phosphor Bronze, Note 4	Gold, Note 11			
Insulation	Teflon, Note 5	None	Description MMCX bulkhead crimp jack for RG-178. Gold plated brass body, teflon dielectric		
Ferrule	Annealed Copper, Note 7	Same as body			
Gasket	-	-	Scale	Drawing No.	File Name
Hex Nut	Brass, Note 1	Same as body	5:1	MMCX/MCSF13-178	MCSF13-178
Lock Washer	Brass, Note 1	Same as body			