

Tolerances 1-20=+/-0.2 20-30=+/-0.3 30-40=+/-0.4 40-50=+/-0.5 50-100=+/-0.75 100-300=+/-1.5 Angles=+/-1 Dimensions are in Millimeters	Revisions Description/Approved/Date	Approved M.H.	Date
		Checked M.H.	Date
		Drawn T.J.A.	Date
NOTES (plating thickness in micro-inches): 1. Per QQ-B-626 2. Per QQ-S-764 3. Per QQ-C-530 4. Per QQ-B-750 5. Per MIL-P-19468 6. Per ZZ-R-765 7. Per WW-T-799 8. Gold pl. 5 min. over nickel pl. 50 min. over copper strike 9. Nickel pl. 100 min. over copper strike 10. Per QQ-P-35 11. Gold pl. 3 min. over nickel pl. 50 min. over copper strike			

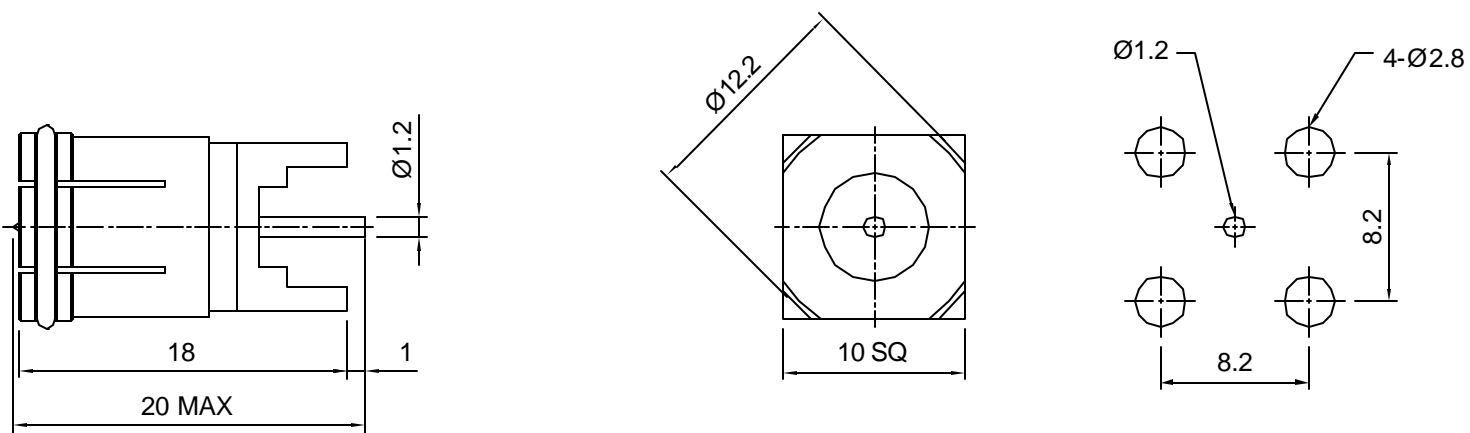

ITEM	MATERIAL	FINISH
Connector Body	Brass, Note 1	Bright Acid Tin
Center Contact: Male	Brass, Note 1	Gold, Note 11
Insulation	Polypropylene	None
Ferrule	--	--
Gasket	--	--
Hex Nut	--	--
Lock Washer	--	--

Lighthouse Technologies, Inc.
4907 Morena Boulevard, #1411
San Diego, California 92117

Part Number:
LTI-GSM54BTP

Description		
G vertical straight PCB thru hole plug.		
Bright acid tin, polypropylene dielectric.		
Scale	Drawing No.	File Name
3:1	GSM54BTP	GSM54BTP