

	Tolerances 1-20=+/-0.2 20-30=+/-0.3 30-40=+/-0.4 40-50=+/-0.5 50-100=+/-0.75 100-300=+/-1.5 Angles=+/-1 Dimensions are in Millimeters	Revisions	Approved	Date
		Description/Approved/Date	M.H.	04/25/02
			Checked	Date
			M.H.	04/25/02
		Drawn	Date	
		K.R.E.	04/23/02	
NOTES (plating thickness in micro-inches):		5. Per MIL-P-19468	9. Nickel pl. 100 min. over copper strike	
1. Per QQ-B-626	6. Per ZZ-R-765	7. Per WW-T-799	10. Per QQ-P-35	
2. Per QQ-S-764	8. Gold pl. 20 min. over nickel pl. 50 min. over copper strike	11. Gold pl. 30 min. over nickel pl. 50 min. over copper strike		
3. Per QQ-C-530				
4. Per QQ-B-750				

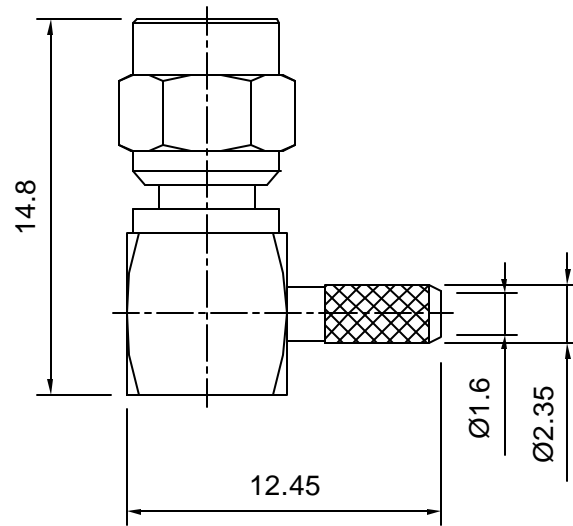

ITEM	MATERIAL	FINISH
Connector Body	Brass, Note 1	Gold, Note 8
Center Contact: Female	Phosphor Bronze, Note 4	Gold, Note 11
Insulation	Teflon, Note 5	None
Ferrule	Annealed Copper, Note 7	Same as body
Gasket	--	--
Hex Nut	--	--
Lock Washer	--	--

Lighthouse Technologies, Inc.
4907 Morena Boulevard, #1411
San Diego, California 92117

Part Number:
LTI-SCLM11GT-316

Description		
SMC right angle crimp plug receptacle for RG-316. Gold plated		
brass body, teflon dielectric.		
Scale	Drawing No.	File Name
3:1	SMC/SCLM11-316	SCLM11-316